

# SOME INVESTIGATIONS ON CONVERGED NETWORKS

ABHISHEK GAUR<sup>1</sup>, SULABH TYAGI<sup>2</sup>

<sup>1,2</sup>GB PANT GOVT. ENGG. COLLEGE, NEW DELHI, <sup>1</sup>ELECTRONICS & COMMUNICATION ENGG. DEPTT.  
<sup>2</sup>Computer Science & Engg. Deptt.

**Abstract:** This article provides a comprehensive analysis on implementing the next-generation optical-wireless integration architectures. The different approaches to implement a complete fixed-mobile converged network that ensures desired quality of service for various applications are explored. This discussion is specifically focused on LTE-10GEPON integration networks where passive optical networks are used as the backhaul to LTE. Special attention is given to address the issue of providing proper means to enable intercommunication between neighboring base stations, which is one of the crucial considerations in next-generation wireless networks. We propose potential 10GEPON-LTE converged network architectures and comparatively analyze the benefits gained from each of the integration architectures by elaborating on the operational and control structures. Our performance analysis provides insight into QoS-rich next-generation optical-wireless converged networks.

## I. INTRODUCTION

Today, bandwidth- and quality of service (QoS)-intensive next-generation (NG) broadband applications have become important elements in telecommunication networks. To cope with the ever increasing demand for bandwidth, various access network technologies that can provide more than hundreds of megabits per second bandwidth have been developed in the last few decades. Among these broadband access technologies, passive optical networks (PONs) have been recognized as the most cost-effective solution to facilitate high bandwidth and fault-tolerant access to end users. However, in some situations, the PON itself might not be a suitable solution where mobility is an important concern, or might not be a cost-effective solution depending on geographical restrictions. To overcome these shortcomings, optical-wireless integration networks have been proposed where the end users are served by either wired or wireless access. On the other hand, PONs have been identified as one of the most competent economical solutions for backhauling NG wireless broadband access networks (NG-WBANs). The Ethernet PON (EPON)-WiMAX integrated network is one of the optical-wireless integration options that has been studied extensively [1, 2]. Nevertheless, Long Term Evolution (LTE) developed by the Third Generation Partnership Project (3GPP), which can support up to 100 Mb/s of data rate in the downlink, is becoming

more popular among service providers. Although both LTE and mobile WiMAX (802.16m) technologies are considered NG-WBANs, LTE has an added advantage over mobile WiMAX in that it uses the evolution of existing Universal Mobile Telecommunications System (UMTS) infrastructures, currently being used by mobile service providers worldwide [3]. On the other hand, time-division multiplexed (TDM) 10-Gigabit EPON (10GEPON), which supports up to a 10 Gb/s symmetric data rate, is becoming more popular as an NG-PON technology since it provides higher transmission capacity with the lowest per-user cost among PON technologies. Thus, 10GEPON and LTE are natural candidates for a cost-effective NG complete fixed-mobile converged network. Furthermore, it is envisioned that the 10GEPON-LTE converged network will combine the advantages of high capacity and high-speed backhaul from 10GEPON with extensive mobility the LTE network can support. In [5], an integration network that uses LTE and native Ethernet-based wavelength-division multiplexing (WDM) PON is presented, and the authors have considered a ring-topology-based PON for their proposed architecture. To the best of our knowledge, backhauling NG-WBANs using tree-based TDM-PON with the ability of direct communication between base stations has not been studied so far. However, such integration is one of the most cost-effective approaches to achieve a fully converged network as most PONs deployed today are tree-based. In this article, we discuss the key challenges in implementing the 10GEPON-LTE converged network, which meets both the LTE and 10GEPON networks' stringent requirements. To this end, we propose three feasible 10GEPON-LTE converged architectures which are implemented on top of the tree-topology-based PON. The benefits gained from each of these architectures are discussed by comparing operational and control structures, and QoS performance.

## II 10GEPON AND LTE NETWORK

LTE is an all-IP network that provides seamless mobility and required QoS for triple-play services [6]. A typical LTE network architecture is shown in Fig. 1. As illustrated in Fig. 1, the radio access network (RAN) of LTE consists of only evolved nodeBs (eNBs), which are basically radio base stations. These eNBs are capable of

allocating radio resources among its connected user equipment (UE) in a distributed manner without the involvement of any core network elements. The neighboring eNBs are interconnected via the X2 interface, which facilitates direct communication between neighboring cells. Likewise, all eNBs are connected with the LTE core network (also referred to as evolved packet core or EPC) via the S1 interface, which is dedicated to data and control plane signaling transport. The EPC consists of a mobility management entity (MME), a serving gateway (S-GW), and a packet data network gateway (PDN-GW). These core network elements facilitate proper management of LTE network elements and provide links to other networks. In LTE, the concept referred to as the evolved packet system bearer is used to support QoS for diverse services across the network [6]. Here, each bearer consists of a QoS class identifier (QCI), which is characterized by priority and other QoS requirements. Nine different QCIs are used in the LTE network to provide guaranteed QoS for diverse applications such as voice, video on demand, and e-health. 10GEPON is the heir of EPON and is standardized as IEEE 802.3av [7]. In 10GEPON, no active element is placed in the optical path between the optical line terminal (OLT) located at the central office and optical network units (ONUs) located at customer premises. Two different wavelength channels are used in 10GEPON for the uplink and downlink transmissions. In the uplink transmission, the medium access is controlled by Multipoint Control Protocol (MPCP), where the OLT allocates time slots among its connected ONUs to avoid data collision. In MPCP each ONU reports its present queue status to the OLT using REPORT messages, and the OLT grants a time slot for each ONU based on a dynamic bandwidth allocation (DBA) algorithm and notifies the granted time slot to each ONU using a GATE message. The ONUs transmit their uplink data only during the designated time slot. In the downlink transmission, on the other hand, the OLT broadcasts all the frames to all of its connected ONUs. Each ONU filters out the frames that are not destined to it based on the unique physical logical link identity (LLID) assigned by the OLT upon registration. 10GEPON uses differentiated classes of service to support a queue-oriented QoS mechanism where eight different priority queues are maintained by each ONU.

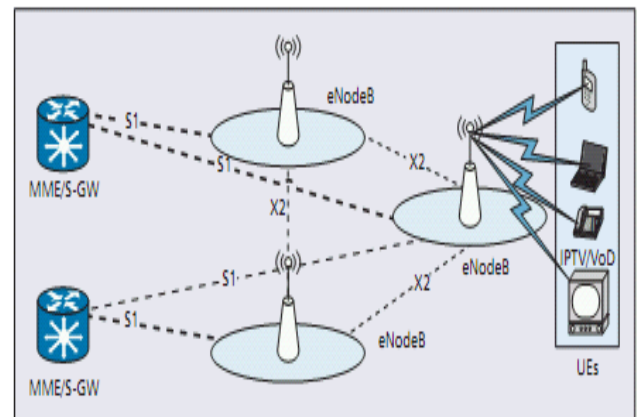

Fig.1 LTE Network Architecture

### III KEY CHALLENGES IN IMPLEMENTING NG OPTICAL WIRELESS CONVERGED NETWORKS

Building a simple and cost-effective architecture that can effectively support high bandwidth and QoS-intensive applications is one of the key challenges in implementing a fully converged network. In addition, developing a resource allocation protocol for the converged architecture that complies with both the MPCP-based PON DBA and distributed resource allocation mechanisms in LTE is also an important consideration. In early wireless access network technologies prior to LTE, there was no mechanism for direct communications between neighboring base stations. LTE facilitates this by introducing the X2 interface, which provides an efficient means to communicate control plane signaling and user plane traffic, especially when handovers take place between neighboring cells[6]. A recent estimate forecasts that the traffic traversing the X2 interface could reach up to 10 percent of the core-facing traffic, and the latency of this traffic should be less than 30 ms to maintain the required QoS [8]. Moreover, the X2 interface has been considered one of the most important requirements in future LTE releases (LTE Advanced) where the targeted latency is less than 10 ms together with 1 Gb/s downlink data rate [3, 8]. Thus, proper implementation of the X2 interface that can guarantee the required QoS is a crucial consideration in building a fully converged NG optical-wireless network. To this end, we propose potential 10GEPON-LTE converged architectures that conform to 10GEPON and LTE standards and their requirements.

#### A. GEPON-LTE Integration Architectures

In this section, we discuss potential 10GEPON-LTE integration architectures in detail. However, it is important to note that although our discussion is centered around the 10GEPON-LTE converged network, architecture-wise these architectures are compatible with other TDM-PON systems and fourth-generation (4G) WBAN technologies

such as 10GPON (10 Gigabit PON) and mobile WiMAX, respectively. In the following subsections, we discuss the operation, control structures, and key features of each of the converged architectures.

**B. Native 10GEPON-LTE Integration Architecture (NLIA)**

This is the simplest architecture which is used to backhaul the LTE access Network & it does not require any additional equipments or modifications. The deployment cost of this architecture is minimum. In this architecture, the integrated ONU and eNB(ONU-eNB) is connected to the OLT via a 1:N passive splitter and each OLT is connected to the LTE core network elements. On the down side, in NGLIA, the X2 interface is logically and physically supported through the OLT. Consequently, considerable packet delays might occur during handovers. Nevertheless, an appropriate MPCP-based DBA algorithm can be employed to improve QoS performance by efficiently allocating bandwidth among its connected ONU-eNBs. In addition, QoS performance can be further improved by implementing an efficient intra-ONU-eNB scheduling mechanism in ONU-eNB to distribute the available bandwidth effectively among its UE, together with an appropriate QoS mapping mechanism between LTE QCI and 10GEPON priority classes. The NLIA is shown in Fig. 2(a).

**C. Loopback Integration Architecture(LIA)**

A loopback mechanism is introduced in this architecture at the passive splitter. For realization of the loopback mechanism, (N+1)X(N+1) passive star coupler is introduced. An additional fiber connecting each integrated ONU-eNB and Star Coupler(SC) is required to provide loopback path. It is to be noted that introduction of SC does not change the passive nature of the Network. It is able to support the direct communication among ONU-eNBs connected to the same OLT. LIA can significantly reduce the processing delay at the OLT and increase the downlink throughput which ultimately improves QOS in the converged Network especially in x2 interface. The main advantage of LIA is its ability to support the direct communication among ONU-eNBs connected to same OLT(inter ONU-eNB communication) through the SC. However, this architecture cannot be used for long distance communication as well as in remote areas. From LTE's perspective, the handover signaling that needs to be communicated between neighboring eNBs can be effectively routed through the SC by creating logically meshed X2 interface complying with the LTE standard. The LIA is shown in Fig.2(b).

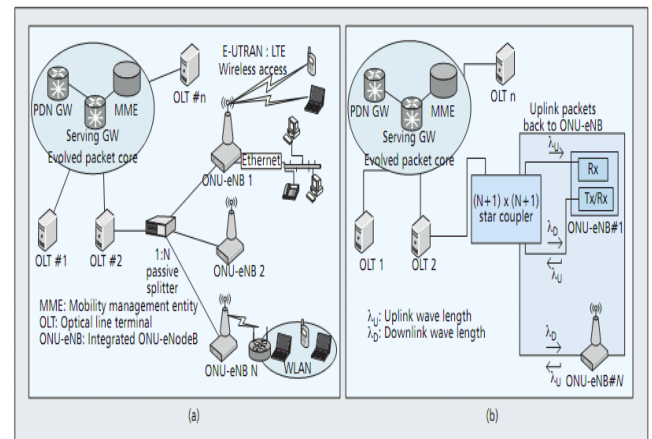

Fig.2 (a) Native-10 GEPON-LTE Integration Architecture (b) Loopback Integration Architecture

**D. Remote Node Integration Architecture (RNIA)**

RNIA is a 10GEPON-LTE integration architecture which uses two active remote nodes(RNs)In comparison to the NGLIA and LIA ,this RNIA shows significant differences in its architecture and operation. These RNs have the intelligence to perform MAC layer functionalities such as storing MAC addresses and LLIDs of connected ONU-eNBs and forwarding packets according to the stored data. The received frames are regenerated at the RN,this architecture is also suitable for situations where ONU-eNBs are required to deploy far from each other or distant from the OLT such as in rural areas. The overall delay performances can be further improved by implementing a DBA algorithm that takes advantage of the existence of multiple RNs in the Network. The RNIA is shown in the Fig.3.

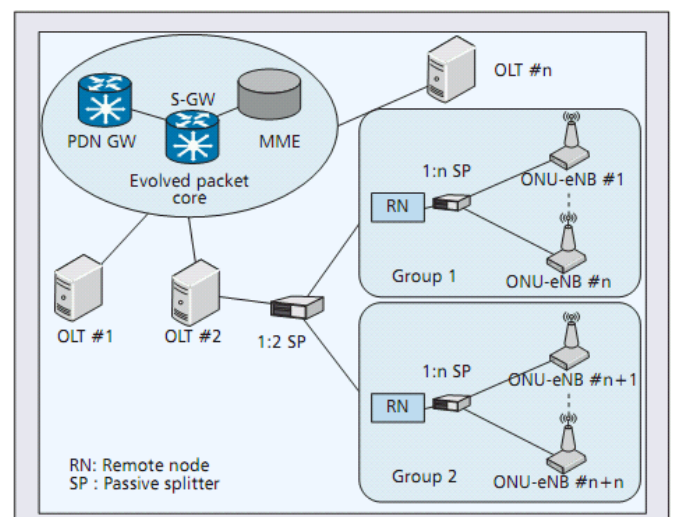

Fig. 3 Remote Node Integration Architecture(RNIA)

### E Proposed Integrated Network Architecture

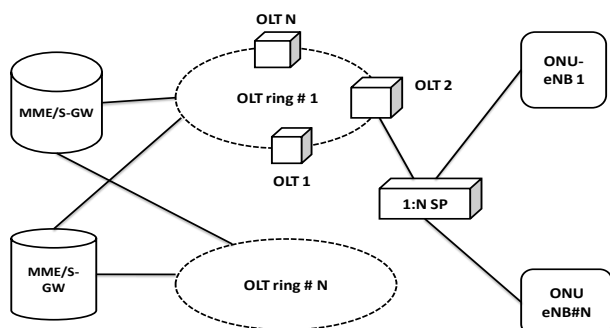

Fig. 4 OLT Ring Protection architecture (Proposed)

In large telecommunication network deployments, service resiliency is a crucial aspect. The previously discussed converged network architectures are more focused on achieving high network performance. In simple terms, networks should have a recovery mechanism to provide uninterrupted service to end users when one or more network elements fail. To provide such reliance to end users, ring-based converged network architecture as shown in Fig. 4 can be implemented. In this architecture, OLTs are connected in a ring, and each ring is connected to MME/S-GWs using a mesh topology complying with the LTE core network requirements. The converged access networks connected to the OLT ring topology can be any combination of NGLIA, LIA and RNIA. This OLT ring-based architecture improves the survivability of the converged network by providing redundancy links between each OLT and EPC. Since frames originating from one ONU-eNB and destined to another ONU-eNB connected to the same OLT ring can be routed via the OLT ring instead of through the EPC, end-to-end packet delay can be reduced. Thus, this architecture can be effectively used not only to improve the reliability but also to improve the QoS of the converged network.

### IV CONCLUSION

In this article, we comparatively analyze the potential architectures suitable for Next Generation optical-wireless integration. Specifically, we consider 10GEAPON-LTE integration, which is most likely to be the most prominent and cost-effective integration option due to the rising popularity of these access technologies. To this end, we evaluate three different 10GEAPON-LTE integration architectures to which we referred as NGLIA, LIA, and RNIA. We elaborate on the operational and structural considerations of these architectures and evaluate the QoS

performance of inter ONU-eNBs communication, which is one of the key considerations of NG-WBANs.

### V FUTURE SCOPE

It is important to consider the reliability and robustness of the converged networks, which depend on the architectures and topologies used for implementation. The implemented network should have a Recovery mechanism to provide uninterrupted service to end Users when one or more network elements fail. Involvement of advanced architectures should be introduced in FMC(Fixed Mobile Convergence) schemes like LTE-Advanced & NG-PON2 in converged network architecture in order to increase bandwidth & QoS(Quality of Service) & also to meet current broadband requirements of subscribers. New and upgraded converged network architectures may be proposed in terms of better QoS & higher bandwidth which will meet the current requirements of subscribers. In addition, developing a resource allocation protocol for the converged architecture that complies with both the MPCP-based PON DBA and distributed resource allocation mechanisms in LTE is also an important consideration.

### REFERENCE

- [1] S. Gangxiang et al., "Fixed Mobile Convergence Architectures for Broad-band Access: Integration of EPON and WiMAX," IEEE Commun. Mag., vol.45, 2007, pp. 44–50.
- [2] S. Sarkar, et al., "Hybrid Wireless-Optical Broadband-Access Network (WOBAN): A Review of Relevant Challenges," J. Lightwave Tech., vol. 25,2007, pp. 3329–40.
- [3] I. T. Stefania Sesia and Matthew Baker, LTE — The UMTS Long Term Evolution: From Theory to Practice, Wiley, 2009.
- [4] L. Rujian, "Next Generation PON in Emerging Networks," OFC/NFOEC,2008, pp. 1–3.
- [5] M. A. Ali et al., "On the Vision of Complete Fixed-Mobile Convergence," J.Lightwave Tech., vol. 28, 2010, pp. 2343–57.
- [6] 3GPP TS 23.107 Quality of Service (QoS) Concept and Architecture, <http://www.3gpp.org>.
- [7] "IEEE 802.3av," standard, 2009.
- [8] Cisco, Architectural Considerations for Backhaul of 2G/3G and LTE Networks., 2010, <http://www.cisco.com>
- [9] E. Wong et al., "Customer-Controlled Dynamic Bandwidth Allocation Scheme for Differentiated Services in PONs," J. Opt. Net., vol. 5, 2006, pp. 541–53.
- [10] C. A. Chan et al., "Active Remote Node with Layer Two Forwarding for Improving Performance of EPON," IEEE GLOBECOM, 2008, pp. 1–5.

### BIOGRAPHIES

ABHISHEK GAUR (abhishek1011332805@gmail.com) received his B.Tech degree in Electronics & Communication Engineering and M.Tech degree in Digital communication from Guru Gobind Singh Indraprastha University, Delhi, India in 2010 & 2012 respectively. He is currently working as Asst. Professor in G.B Pant Govt. Engg. College, Delhi, India in Deptt. of Electronics & Communication Engg. He is also pursuing his Doctorate Degree in the field of Electronics & Communication with

specialization in optical communication from Galgotias University, Greater Noida, India. His research interests include Optical-Wireless converged Networks, Optical Access Networks, Consumer Electronics, Heterogeneous Networks, Electrical Machines, Microwaves, Antennas and Wireless Backhauling.

SULABH TYAGI ([sulabhtyagi2k@yahoo.co.in](mailto:sulabhtyagi2k@yahoo.co.in)) received his B.Tech degree in Electronics & Instrumentation Engineering from UP Technical University, Lucknow, India and M.Tech degree in

Information Technology from Guru Gobind Singh Indraprastha University, Delhi, India in 2005 & 2008 respectively. He is currently working as Asst. Professor in G.B Pant Govt. Engg. College, Delhi, India in Deptt. of Computer Science & Engg.. Previously, He worked in Tech Mahindra as Software Engineer. His research interests include Ad-hoc networks, Wireless Sensor Networks, Cloud Computing, Software Testing and Wireless Backhauling.